

FURTHER COMMENTS ABOUT THE GREAT LAXEY WINDING ENGINE

by David Hollis

Abstract Information presented by several authors to the author of a recent article on the engine has helped correct and clarify points made in that article. These comments, coupled with an examination of the engine by the author, in August 1986, have given further insight into the workings of the winding system used at Great Laxey Lead Mine in the Isle of Man from about 1860 to about 1930.

---

Recently, Hollis (1986a) described the system used to wind ore from deep levels to the adit at the Welch and Engine shafts of the Great Laxey mine in the Isle of Man. This was a water turbine which drove two winding drums (one for each shaft) via a spur and bevel drive and dog-clutch system.

Several readers have informed Hollis of corrections and clarifications necessary for a true understanding of the remains on the site. The author is grateful for these comments, and presents them here for the general readership.

Gillings (1986) has commented in detail, so much of what appears here is transcribed from his letter to the author. Material enclosed by square brackets has been inserted by Hollis for continuity.

Concerning the two winding houses, Gillings writes:

"The [steam driven] beam engine was installed [in a building close to, but above that which housed the turbine driven system] in 1846 (Garrad et al. (1972) or 1847 (Cowin (1973)). Recent excavations by Birmingham University's Institute of Industrial Archaeology, Ironbridge (I.I.A.) (Clark et al. (1985)) suggest that the beam engine replaced an earlier water wheel in the same building". [The turbine was installed later, in the lower of the two buildings, but wound the same two shafts as the beam engine.] Plate 1 is a photograph taken by Jespersen in 1965, facing up Glen Moor, of the upper (beam engine) and lower (turbine) winding houses. The Welch shaft is up valley (left of the picture) and the Engine Shaft is down valley (right of the picture).

On the date of the turbine, Gillings writes:

"Cullen (1871) refers to an 1853 report on the operation of a Macadam Fourneyron turbine. The Laxey machine was installed in 1860 (Cowin) or 1862 (Garrad et al.) which the I.I.A. suggests was one of the EARLIEST examples of a turbine being used for mining purposes. Thus the reference (by Hollis) to the turbine becoming available in 1870 dates its design and development some fifteen to twenty years too late."

"[Hollis's] reference to the adit as the Grand Day level was the first time [Gillings] had seen this name applied at Laxey. It was generally referred to as the Main Adit, or the Horse Level. Bobby Kelly (see Gillings (1981)) used the phrase 'Horse Level' to describe the adit being driven beyond Dumbell's [shaft], but he said he didn't know why it was called that".

Gillings continues "The headgear at the shafts would be fairly small, since there was no need to wind the kibble to the surface level - the usual reason for having a high headgear. Indeed, at the Welch shaft, the rope ran through a tunnel under the steam boiler floor, which would bring the rope to the shaft top at ground level. The inclined plane leading from the beam engine house [to Engine Shaft] is more clearly discerned, and it is probable that the rope between the turbine winder and the Engine Shaft was in fact carried on rollers on wooden stools. The rope line to the Welch shaft would have needed a horizontal deflector pulley just outside the winder house, although there is no evidence on the ground for this".

One hitherto unresolved question is that of reversing the drive to the winding drums from the turbine. Hollis (1986a) and Cowin (1973) favoured the theory of a central lever or "tiller", capable of shifting the bevel gears on the winding drum axles such that forward or reverse drive could be obtained on the winding drums without any need for the direction of the rotation of the turbine to be reversed. Gillings (1986) is convinced that the bevel gear was not a reversing device. He writes: "The most common use of bevel gears is simply to change the direction of a drive shaft [by 90 degrees], and .... this is the true explanation of what is found at Laxey. If there was no reversing gear, there was no need for a reversing 'tiller', and hence it is not surprising that there is no evidence of its remains! The most telling evidence that there was no reversing gear is the dog-clutch arrangement on the winding drums. The bosses on the drums were clearly designed to drive in one direction only. The practice of free-wheeling the kibbles down the shaft was the only way of returning them to the shaft bottom - and why waste water driving them down when gravity would do the work for you?".

Gillings understands that other uni-directional drives can be found in Wales. Two examples may be cited, both north-east of Aberystwyth. Bick (1976) gave two excellent photographs of the waterwheel and winding drum at Brynyrafr, with no facilities for reversing the drive. Bick also showed a picture of similar machinery installed below ground at the Ystrad Einion mine. Geoff Wallis of Dorothea Restorations Ltd. suggested that the turbine could actually provide some braking effort when the kibble was being lowered. Use of the turbine as a brake would ease the effort required of the brake bands on the winding drums. Gillings remarks that he knows of no evidence in favour of, or against, this theory.

Jespersen's photograph of the winding drums, taken in 1954, is shown in Plate 2. The view is from the base of the beam engine house in a "cross-valley" direction, roughly from the top middle to centre left of Plate 1. One of the tillers for clutching in the winding drums is still in place, at the bottom right of the photograph. The other is missing. Plate 2 has been reduced from the original full A4 sized photograph kindly sent to Hollis by Jespersen in late 1986. For that reason, the confusion of detail in Plate 2 in the vicinity of the large gears on the horizontal drum shaft renders interpretation difficult. However, the original shows clearly that between the two bevel gears is the cap of one bearing and the seat for a second. A common shaft would need only one bearing, (if any bearing at all were needed in the centre.) The closeness of the bearings indicates that there were two SEPARATE drum shafts. The shafts cannot move laterally, and there is no means of sliding the bevel gears along the shafts. Therefore, we can for the first time definitely say that the story of a central lever to give reversal of drive from the turbine to the drums is incorrect.

Moore (19886) and Crocker (1986) describe the Godalming water turbine, which is, in many respects, similar to the Laxey turbine. It is interesting to note that the bevel drive from the turbine looks similar to that at Great Laxey, and that it does not have a tiller for reversing the drive.

Referring to the serious damage caused to the clutch bosses of one of the winding drums, Gillings points out that a wooden toothed reduction gear existed between the turbine and the drive bevel. Its purpose was that if a kibble caught in the shaft, or a winding drum was carelessly "clutched in", easily replaced wooden teeth would shear before damage occurred to other components.

Turner (1986) writes: "[The author assumes] in the article [Hollis 1986a] that the power to the winding drums was clutched in or out from the layshaft whilst the latter was rotating. The clutches used, however, are not like car clutches, [but are] of the positive drive type, and given the mass [of the winding system] any attempt to clutch in [the drum] while [the turbine was] rotating would result in destruction of some part of the engine. Similarly, selection of forward or reverse drive would have to be done with everything at rest.

This is borne out by the water control valve, which is an unusual design, and appears to be designed to give rapid opening and closing - a large area being offered to the water flow for small movement of the valve plug. This would be consistent with stopping and starting the turbine frequently on intensive winding".

Bobby Kelly [Gillings (1981)] noted that the miners usually wound one shaft one day, and another the next, rather than hauling ore from several on the same day. On that point, Turner (1986) writes:

"As each of the two winding drums would serve its own shaft, it follows that only one shaft would be wound at a time, although the practice of clutching out a drum, and allowing it to free wheel, could be done independently of the other drum which could be powered by the turbine at the same time".

Hollis remarked that the bearing surfaces in the turbine were hard to discern, but Gillings gives a description of these: "Figure 1 of Gillings (1975) shows [what Gillings believes to be] a more accurate depiction of the bearing arrangement. This drawing is based on site examinations [by Gillings] of the compressor turbine in 1974, and on Cullen. The vertical thrust was probably taken on a series of cast iron and brass discs, although bearings of lignum vitae (a very hard wood) were common. The latter had the advantage of being lubricated by water". Gillings has kindly provided sketches of these, which appear here as Figures 1 and 2.

Concerning the possibility of erratic pressure developed by the "Man Engine" affecting the supply to the winding turbine, Gillings writes:

"The water supply for the winder turbine was not taken from the same supply as the Man Engine. The enclosed sketch [Figure 3 of this article] shows the layout of the water supply, and is based on Jespersen and on field observation".

Geddes (1986) notes that a broken off pipe projecting from the side of the Welch shaft into the bank of the Mooar Water, formerly believed to be for compressed air, is, in fact, an independent water supply to the control gear of the Man Engine. It isolates the control gear from the pressure fluctuations of the main piston. The supply pipe for the control gear formerly went across the stream, and down the other side, presumably to Wier R of Figure 3. The supply for the piston of the Man Engine came from far up the valley, via a high pressure pipe. However, that for the winder turbine came from Wier Q of Figure 3, thereby preventing any ill effects from the piston of the Man Engine reaching the winder turbine.

Cowin (1973) wrote that the expert engineers knew where the kibble was in the shafts by the vibrations up the winding ropes. Cowin also mentioned the indicators on the walls of the winding ropes. Jespersen also refers to these indicators. Gillings (1986) notes that the bearing seats, of the drive rods from the drums to the indicators could still be identified in the winding house in the summer of 1986.

The method of communication with the surface from the adit has varied over the years. Gillings (1986) comments:

"Jespersen says that signals were passed by pulling on the WINDING rope, whilst Mr. Kewley's drawing [in Jespersen's account] shows a separate BELL rope. I strongly favour the latter, using a mechanical bell operated by a pull-wire or rope running the full depth of the shaft".

About the telephone system, Gillings comments:

"Garrad et al. refer to Dumbell's shaft telephone failing" [but not to any other telephone system]. However, Geddes (1986) reported to Hollis that, during an exploration of Welch shaft by the Manx Mines Research Group, a large portion of the

telephone cable of that shaft was found in a tangled heap at Main Adit Level, which, in the Welch shaft, is about 180 feet below the surface. The cable has a hawser-laid outer cover over a lead sheath covering the telephone wires themselves.

The folklore of the mines, passed down amongst the villagers of Laxey verbally to Hollis, suggested that when the telephones failed, the hauliers "rang" on the compressed air pipes. Compressed air was available at Welch shaft, where the compressed air pipe can be seen in the side of the shaft further down than the Man Engine, but is missing nearer the surface than that (Geddes (1986)), and also in Dumbell's shaft. However, no information is forthcoming about Engine shaft specifically, although Jespersen appears to apply his description to both Engine and Welch shafts. In his description there is a diagram which shows that a separate bell rope is provided, near the winding rope, for ringing from adit to surface. For communication from deep levels to adit, Jespersen writes that they pulled on the winding rope - rather difficult, given that the kibbles went down many fathoms below adit level, and therefore that the weight of rope would have been large. Ringing a bell on the compressed air pipes would have sufficed.

During field investigations in July 1986, the nature of the winding rope was studied in detail by Hollis (1986b). The centre is of plaited hemp, about 1/4 inch in diameter. Over that are wound six strands, which follow each other round the same way in a spiral of pitch about four inches. Each strand contained six steel wires, wound as a spiral of pitch 2 inches in the same direction as the spiral of the strands. The diameter of each wire appeared uneven, probably as a result of wear and rust, but was between 1/8 and 1/4 inch. Similar hawser has been found at Beckwith's Mine, Foxdale, which continued operation in a discontinuous fashion until about 1924, in private ownership. Furthermore, it is not known when the Great Laxey Winding Engine last worked. Therefore no date can be placed on the rope. Since it must have had to be replaced many times during the life of the mine, it must be at least of the 20th century. In design, it is similar to lengths of recently discarded hawser to be found in the harbour areas of such towns as Douglas, Peel, and elsewhere.

Concerning the extensive damage to the discarded winding drum (Plate 3 of the original article), a likely cause of this is damage during demolition of the equipment. One wonders if those who were after their "pound of engineering flesh" would have treated the site more reverently if they knew that in August 1986, the surface remains of the Great Laxey mine were to be opened to the public as an exhibit.

I would like to express my thanks to those who have kindly commented about the Great Laxey Winding Engine.

#### REFERENCES:

- Bick, D.E., 1976. "The Old Metal Mines of Mid-Wales: Part 3 - Cardiganshire north of Goginan". The Pound House, Newent, Glos.
- Clark, C., Horton, M., Stratton, M., Irlam, G., Howland-Jones, M. Institute of Industrial Archaeology Research Paper No. 2. "The Great Laxey wheel and mine". Institute of Industrial Archaeology Iron Bridge Gorge Museum, Telford, Shropshire, October 1985.
- Cowin, F., 1973. "The Laxey Mines Trail". Manx Conservation Council.
- Crocker, G., 1986. "The Godalming water turbine". The Godalming Trust, No. 6, Burwood Close, Merrow, Guildford, Surrey GU1 2SB.
- Cullen, W., 1871. "A practical treatise on the construction of horizontal and vertical waterwheels". E. and F.N. Spon.

- Garrad, L.S. et al. 1972. "Industrial archaeology of the Isle of Man". David and Charles, Newton Abbot, Devon.
- Geddes, P. 1986. Private discussions, Laxey, Isle of Man, August 1986.
- Gillings, A.M. 1981. "Unusual water powered engines in the Isle of Man". Bull. Peak Dist. Mines Hist. Soc., Vol. 6, No. 2, pp. 85-92.
- Gillings, A.M. 1981. "Recollections of a Laxey miner". Bull. Peak Dist. Mines Hist. Soc., Vol. 8, No. 1, pp. 43-48.
- Gillings, A.M., 1986. "Comments about the Great Laxey winding engine". Private correspondence to D.B. Hollis.
- Hollis, D.B., 1986a. "The Great Laxey Winding Engine". Bull. Peak Dist. Mines Hist. Soc., Vol. 9, No. 5, pp. 306-12.
- Hollis, D.B., 19886b. "Field notes on Great Laxey mine". Unpublished work.
- Jespersen, A. 1970. "The Lady Isabella Water Wheel". Society Danske Møllers Venner, 3rd edition.
- Moore, P. 1986. "The Godalming Water Turbine Trust". A.I.A. Bulletin, Vol. 13, No. 3, pp. 5-6.
- Turner, D.J. 1986. "Opinions about the hydraulic winding engine at the Laxey mines". Private correspondence to D.B. Hollis.

MS received 12th January 1987.

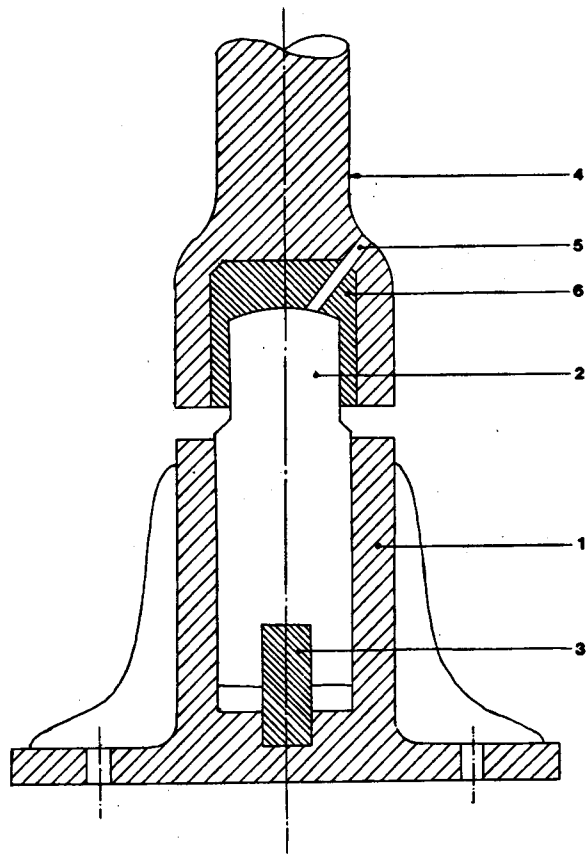

LIGNUM-VITÆ FOOT-STEP BEARING  
FOR 40 H.P. TURBINE

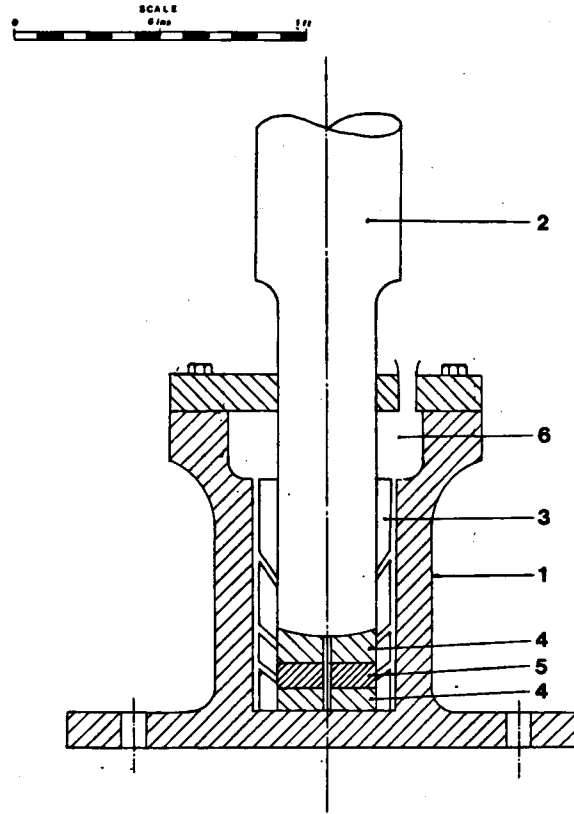

TYPICAL FOOT-STEP BEARING  
FOR 90 H.P. TURBINE  
using cast-iron and brass

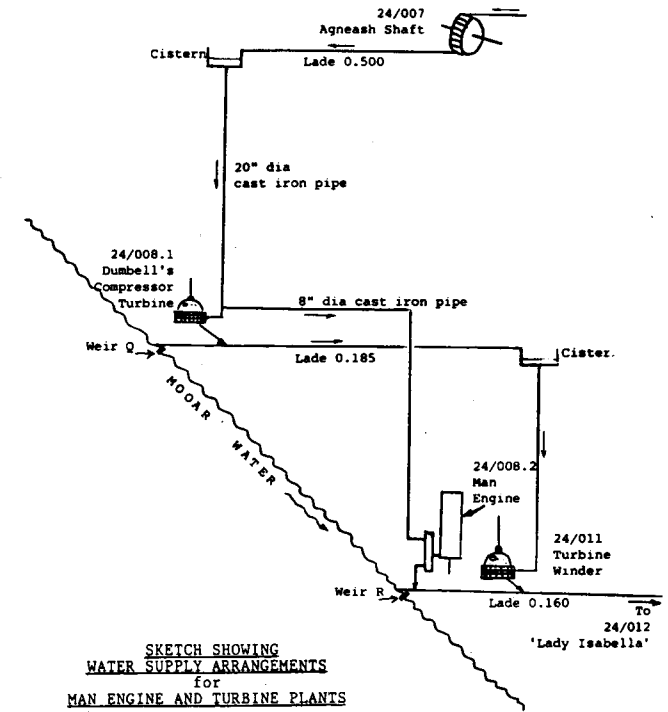

SKETCH SHOWING  
WATER SUPPLY ARRANGEMENTS  
for  
MAN ENGINE AND TURBINE PLANTS  
GREAT LAXEY MINE

Plant numbers, weir letters, and lade identifications all refer to Jespersen's notation.

Figure 1

- 1 Foot stand
- 2 Lignum Vitae pivot
- 3 Lever - stops the lignum vitae pivot from rotating - may also be used to adjust height of pivot
- 4 Turbine shaft
- 5 Channel to lead lubricating water to top of pivot
- 6 Brass thimble

Figure 2

- 1 Foot stand
- 2 Shaft
- 3 Brass thimble
- 4 Brass disc
- 5 Cast iron disc

Figure 3

A.M.G. 10.9.86



Plate 1 The winding houses at Great Laxey mine. Taken by Anders Jespersen in 1965, looking up the valley. The beam engine house is above. The turbine house is below, and nearer the observer.

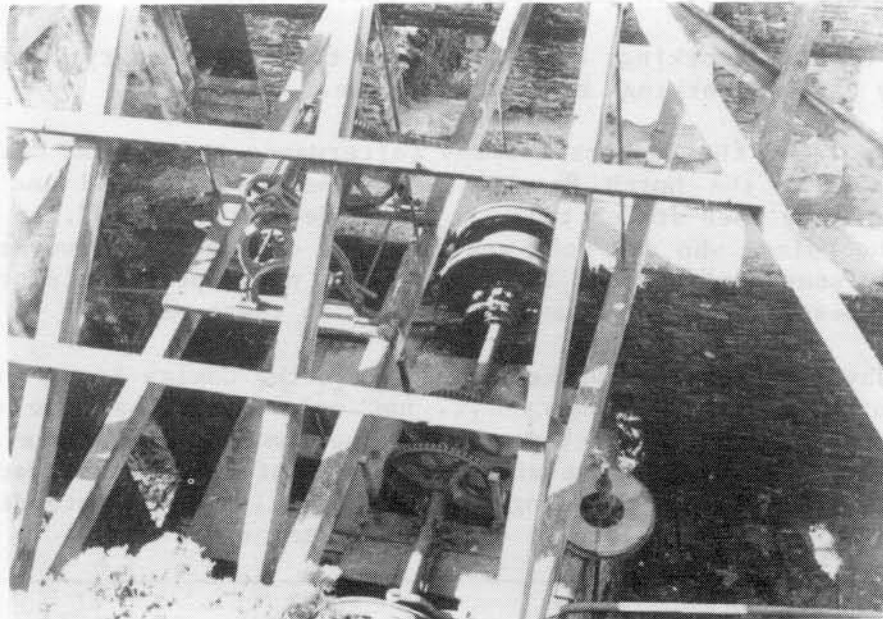

Plate 2 The turbine driven winding drums viewed from the base of the beam engine house. One of the tillers can be seen at the bottom right of the picture. This was taken by Anders Jespersen in 1954.