

# FURTHER OBSERVATIONS ON THE TREVITHICK WATER PRESSURE ENGINE WITH COMMENTS ON THE NEW MUSEUM MODEL

Frank Peel

**Abstract:** A working scale model of the Wills Founder water pressure engine produced by the author demonstrates another method by which it may have been operated in addition to those proposed by Dixon in the last *Bulletin* (1990).

## INTRODUCTION

Tony Dixon's article on the Museum Pumping Engine has reopened the discussions about the operation of this in single action. His case was very well presented and his sketches a model of clarity. However there are some points not raised and parts of his paper invite further discussion.

## DISCUSSION

1. It may be of interest to discuss the original design and the reason for attempting the single action modification. It was Cornish practice in pumping to have the first lift a bucket design and succeeding lifts plunger since buckets permitted valve replacement under water whilst plungers did not. Normally the weight of the plungers, rods etc. was sufficient to operate the plunger pumps, power only being required to lift these plus the bottom bucket lift. Obviously if the mine was too shallow for the weight to be effective, power would be required for both strokes. It seems logical then to assume the Museum Engine was designed to operate both bucket and plunger lifts in a relatively shallow mine. Possibly, at Winster, supply water was inadequate so single action, using 50% water could make sense. The engine was capable of lifting from at least 200 plus feet. This is the reason for the two lifts of buckets one feeding the other as was found.

2. In the design of water pressure engines care has to be taken over the valves and valve gear. In view of the weight bearing on the valves, 3 tons with the Museum example, some form of balancing is essential. Trevithick used two valves and balanced these by means of a chain and pulley. Others used an inside admission piston valve as shown in Dixon's sketches. A further and more dangerous problem is water hammer which can be very destructive. A column of incompressible water, weighing about 3800lbs and travelling at up to 400ft/minute must be stopped gradually if disaster is to be avoided. Trevithick met this problem with valves shorter than port depth, i.e. they leaked at crossover when one valve was approaching closure and the other approaching opening (see Fig 1).

3. In single valve single action there would only be leakage on one valve, whilst the water column would then be brought to a stop as there was no second valve to open. I cannot accept that this would be an adequate defence against hammer.

4. Using one valve in the Trevithick engine I can only see the following ways of obtaining safe single action:-

- A. Relief valves at base of the pressure column. These were not fitted.
- B. Air chamber at base of the pressure column. This was not fitted.
- C. Valve to never fully close. Very inefficient.
- D. Valve to progressively close.

This last could be obtained by using a valve with a slow taper over say the top two thirds of its length and/or bringing the valve to a controlled stop by some means.

5. The following refer to Dixon's paper. In his fig. 2a, b, c, his solid liner would give a fair balance, but only single valve leakage. A better way would be to block the top cylinder port, as on the Museum Engine, whilst leaving the valve gear untouched as designed (see Fig 1). This would allow both valves to leak. However I doubt if this would give adequate defence against hammer as only one side of the piston would be accepting water.

6. I do not feel that either his 3a, b, c, or 4a, b, c, methods, with valves as shown, are acceptable. Balance has certainly been achieved but reliance on short valve leakage for hammer avoidance, seems optimistic.

7. Regarding the mechanical operation of the valves, Darlington states Trevithick used a tumbling bob and Tony has accepted this method as adequate, correctly so for operating servo valves, however neither Stokes' diagram of the 1803 engine nor that of the Wheal Druid engine in the British Encyclopedia show a bob, only direct valve control from the balance beam. If a bob was used, it would have to be more powerful than the existing bob, for though the valves are balanced, this is not perfect and also there is the mechanical friction to overcome.

8. A very controllable method of valve operation is obtained by the use of a hydraulic servo, itself operated by a bob. If manual valves were inserted between the servo valve and piston complete speed control over each double action stroke would be available (see Fig 2). It is of interest that the Museum engine "servos" appear to be the two parts of a servo valve body whilst manual control valves are fitted in their pipe circuit.

9. It is very probable that servo controlled valves would give a more efficient engine. Balance beam control, (see 7), would depend on the kinetic energy of the balance beam mass which would commence to be opposed immediately valve movement commenced. I feel the conversion to servo double action control could have taken place at Alport using adapted parts. This could explain the fairly crude tapping into the rising main. This could only be done with

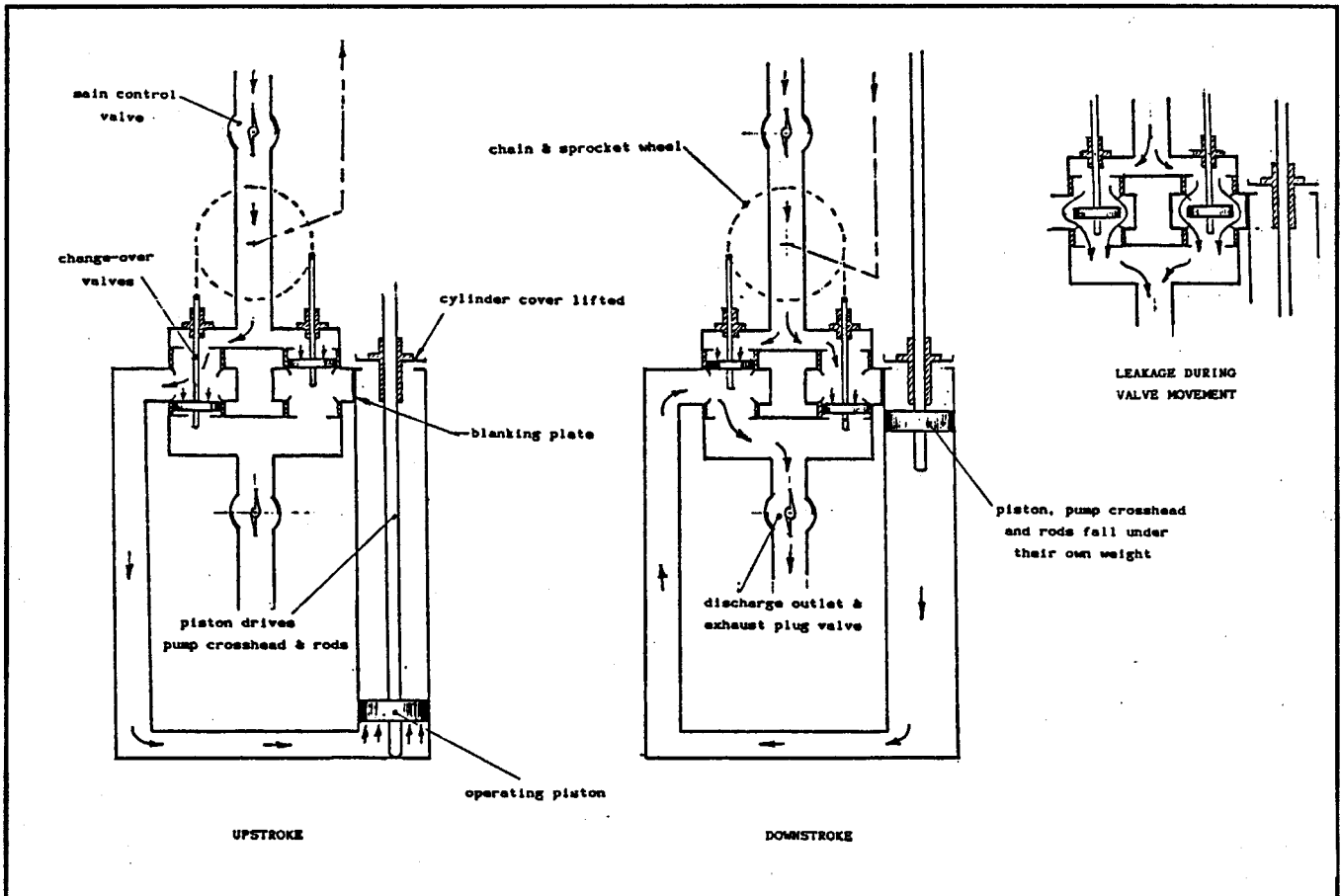

Fig 1. Engine operating with blanked off cylinder, single action.

the water supply cut off and so would have to be done quickly to avoid a prolonged stoppage. Most of the other work necessary could be prepared beforehand. As I understand the engine was replaced by a more powerful example and then sold, there would be no incentive to make a "proper job" when conditions became easier. I admit this is entirely conjecture with no supporting evidence.

10. It was as a direct result of these thoughts that the model now in the Museum came into being. It was intended as a test bed for various ideas, whilst eventually being for display. Even so it would probably have been stillborn but for John Robey who offered to be responsible for the wood work and presentation.

11. Tony Dixon provided sketches and so work began. Basically the model is to 1:18 scale though some liberties have been taken. After a series of experiments with manually moved valves it was found that valves approximately equal in length to port depth gave good results with minor leakage and little hammer, however I would expect that with the enormous forces in full size more leakage would have been wanted.

12. Experiments to operate the valves directly by the beam and then by the largest possible bob were both complete failures, so the next move was to build a hydraulic servo based on the Museum examples. Manually operated this worked well, but the tumbling bob was inadequate due to cubic scale effect. Eventually the solution was an over centre spring device now concealed in the woodwork. The model now ran well controlled by the exhaust plug valve. Individual valves were not fitted in the servo pipe work.

13. The next step was to obtain single action. As found on the Wills Founder Engine the top cylinder port was blocked and the cylinder cover was lifted, extra weight was added to the crosshead and single action was achieved. Control had to be by the main valve as no servo pipe valves were fitted. The exhaust plug valve could not now control the power stroke, only the exhaust stroke. However I am not wholly convinced the real Trevithick Engine would have so worked because of water hammer. Valve modifications as suggested in (4) would certainly have made the conversion successful, whilst the manual valves in the servo circuit would have controlled the speed. As no piston valves remain we will never know if this was tried.

14. I must therefore agree with Tony Dixon in believing the engine never ran single action as found. There is no evidence of achieving the design criteria of balanced valves or controlled closure whilst the very poor workmanship of the modifications point to substandard engineering.

15. The model was worked double action after conversion to servo control, but without the manual valves in the servo circuit which controlled speed. Speed control was by the exhaust plug valve as originally designed.

16. Since the intention was to have the model in motion it was decided to change the power source from water to compressed air. This posed the necessity of applying a load operable for both strokes; hence the oil damped piston and cylinder attached to the rear pump rod, which incidentally is of steel as the original wood failed under load, once again due to scale problems. Ideally a load should be applied to both front and rear rods to equalise the load on the crosshead. Under these conditions the exhaust valve no

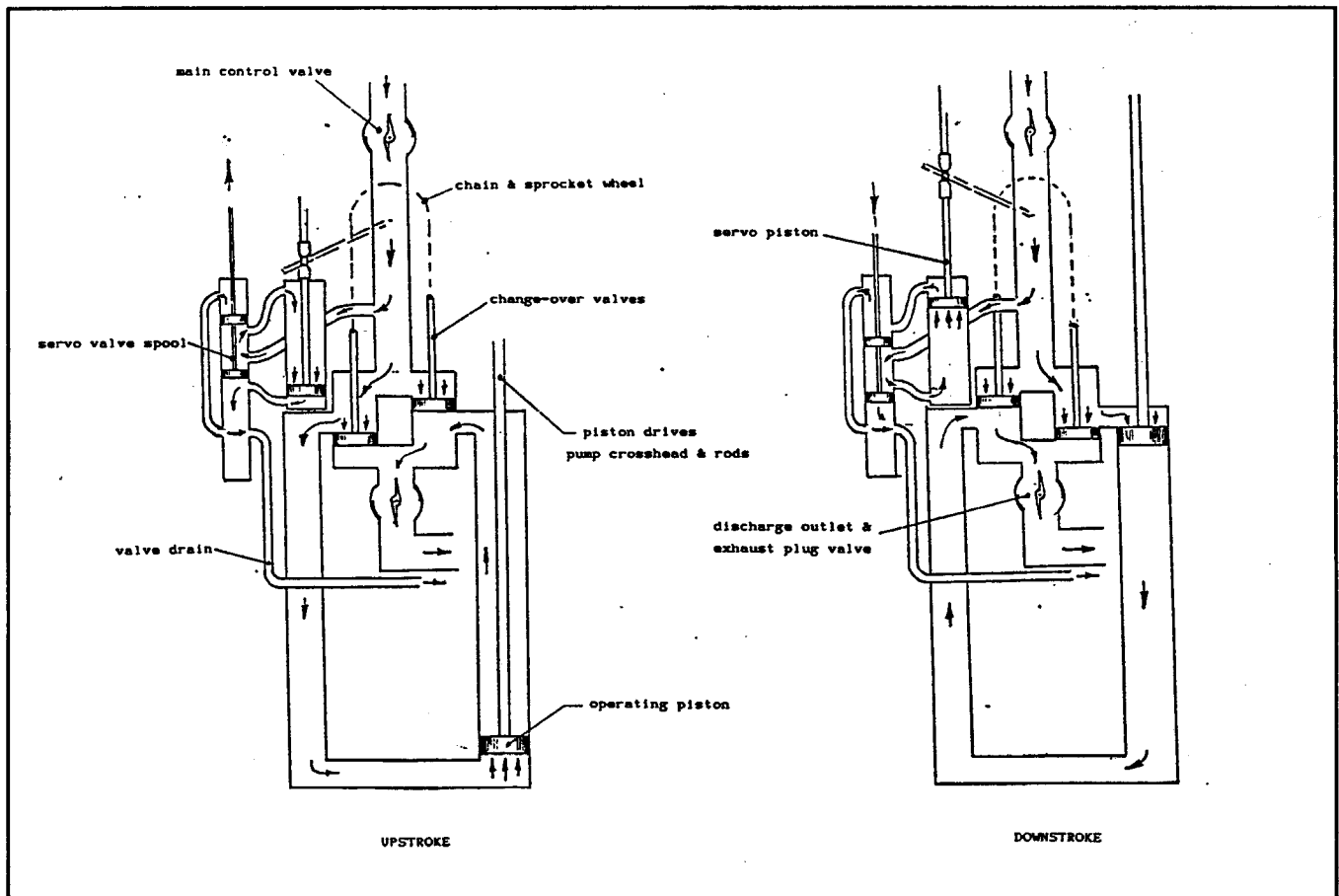

Fig 2. Engine double acting, controlled by servo.

longer controls the speed which is now a function of air pressure and load. Under the mine conditions these were - per stroke - fixed.

Below are some engine details.

Cylinder bore 18". Piston stroke 120".  
 Height of rising main 140ft. Operating pressure 60 lbs sq.in.  
 Contents of rising main (assume average 9" diam.) 3850 lbs.  
 Load on piston 80% efficiency: 5½ tons. Static load on valves 3 tons.  
 Water used per S/A stroke 1100lbs.  
 Estimated strokes per minute: 5. Horse power at this speed S/A: 18½. Depth of fall per S/A stroke in rising main: 40ft.  
 Energy of this fall: 68.7 ft/tons.

Imperial measurements have been used throughout as these were used during the engine's working life.

#### ACKNOWLEDGEMENTS

Thanks are due to Dr. J. Robey for his work on the model, and to Tony Dixon for help in many ways, including preparing the drawings for this article.

#### REFERENCES

Dixon, A.G. 1990 The Operation of the Wills Founder Water Pressure Engine. *Bulletin PDMHS*. Vol. 11, No. 2. pp.55-61.